

# GENIE GS-1932



MEASUREMENTS		METRIC	IMPERIAL
Working height maximum*		7.70 m	25 ft 3 in
<b>A</b>	Platform height maximum	5.80 m	19 ft
Platform dimensions (length x width)			
<b>B x C</b>	Standard	1.63 x 0.74 m	5 ft 4 in x 2 ft 5 in
	Standard with extension	2.54 x 0.74 m	8 ft 4 in x 2 ft 5 in
Slide-out platform extension deck		0.91 m	3 ft
Guardrail height		1.10 m	3 ft 7 in
Toeboard height		15 cm	6 in
<b>D</b>	Height - stowed	1.98 m	6 ft 6 in
<b>E</b>	Length - stowed / extended	1.87 m / 2.74 m	6 ft 2 in / 9 ft
<b>F</b>	Width	0.81 m	2 ft 8 in
<b>G</b>	Wheelbase	1.32 m	4 ft 4 in
<b>H</b>	Ground clearance - centre	6 cm	2 in
<b>I</b>	- with pothole guards deployed	2 cm	1 in

PRODUCTIVITY		
Platform capacity	227 kg	500 lb
Slide-out platform extension deck capacity	113 kg	249 lb
Maximum number of persons - indoor / outdoor use	2 / 1	2 / 1
Maximum wind speed (12.5 m/s)	45 km/h	28 mph
Drive speed - stowed	4.0 km/h	2.4 mph
Drive speed - raised	0.8 km/h	0.49 mph
Gradeability**	25%	14.04°
Inside turning radius	zero	zero
Outside turning radius	1.55 m	5 ft 1 in
Raise / lower speed	16 / 25 sec	16 / 25 sec
Controls	proportional	proportional
Drive	dual front wheel	dual front wheel
Tyres - solid non-marking	30 x 11 x 20 cm	12 x 4.5 x 8 in
Wheel load maximum***	582 kg	1,283 lb
Localised pressure per tyre***	9.91 kg/cm <sup>2</sup> (972 kPa)	141 psi
Occupied pressure***	13.69 kPa	286 psf

POWER		
Power source	24 V (four 6 V 225 Ah batteries)	
Hydraulic system capacity	14.2 L	3.75 gal lqd

WEIGHT****		
	1,503 kg	3,313 lb

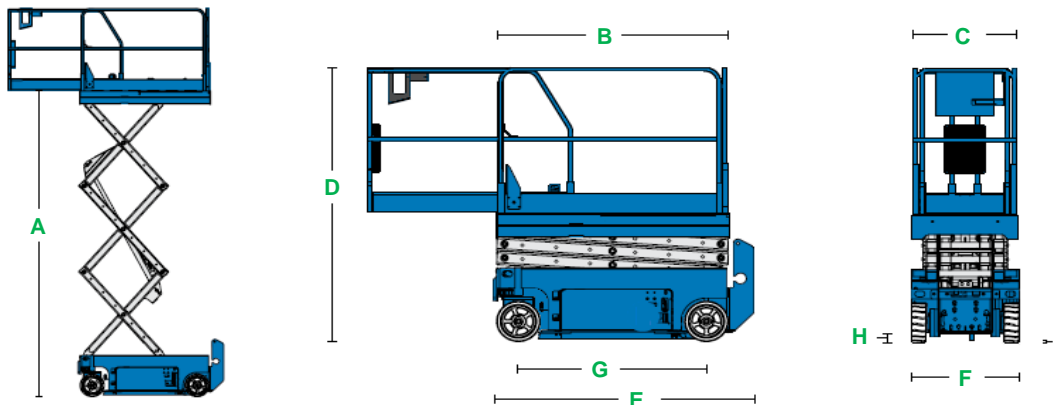

\*The metric equivalent of working height adds 2 m to platform height. Imperial adds 6 ft to platform height.

\*\*Gradeability applies to driving on slopes. See operator's manual for details regarding slope rating.

\*\*\*Floor loading information is approximate. It should be used only with adequate safety factors.

\*\*\*\*Weight will vary depending on options.